

TOWN OF COTTAGE GROVE - CODE OF ORDINANCES

CHAPTER 11 - PUBLIC NUISANCES

11.01 REGULATION OF JUNK ACCUMULATION

(1) DEFINITIONS

(a) "Junk" means any old or scrap metal, metal alloy, synthetic or organic material or waste. Junk includes any air conditioner, clothes dryer or washer, dish washer, fan, furnace, refrigerator, stove, water heater or softener, and any other appliance, which is located outside of a dwelling or other enclosed structure, and is incapable of being used for its designed purpose, or has not been used for said purpose for a period of at least 30 days.

(b) "Junk farm machinery" means any combine, harvester, hay bailer, manure spreader, plow, portable storage tank, wagon or wagon frame, and other pieces of equipment, and their components, commonly found in agricultural use; which are inoperable, and stored outside of a barn or similar enclosed structure for a period of at least 90 days.

(c) "Junk vehicle" means any all-terrain vehicle (ATV), motor vehicle [as defined in § 340.01(35), Wis. Stats.], motorcycle, recreational vehicle (RV), snowmobile, trailer, truck or truck body, and similar pieces of equipment which are junked, dismantled, disassembled, inoperable, abandoned, or wrecked, and are incapable of being legally operated on a public highway due to missing or inoperative parts, flat or removed tires, or other defects including lack of a valid registration, and which are stored outside of a garage or similar enclosed structure for a period of at least 30 days.

(d) "Solid waste" has the meaning specified in § 289.01(33) Wis. Stats., but also includes all garbage, all animal, fish, fowl or vegetable matter incident to and resulting from the use, preparation and storage of food for human consumption, rubbish, ashes, debris, industrial wastes, miscellaneous household waste material, combustible and non-combustible material resulting from ordinary mercantile enterprises, boxes, cartons, paper, ashes, tires, cinders, tin cans, wood or metal or plastic refuse, bottles and broken glass, rubber, grass clippings, brush, leaves and garden plants.

(2) ACCUMULATION OF JUNK PROHIBITED

(a) No person shall allow any material described in (1)(a)-(1)(d), to accumulate on their property in an unenclosed or unscreened manner, or in a manner which tends to create a safety, sanitary or health hazard, tends to create a rodent or varmint attraction, or by its unsightliness, tends to depreciate property values.

(b) Any person in violation of (a) shall be subject to the enforcement procedures set forth in s. TCG § 11.10.

(c) The safe and healthy accumulation of any material described in (1)(a)-(1)(d), which is out of the public view; and is in compliance with all other state, county and town regulations is not prohibited by this ordinance.

(3) EFFECTIVE DATE

The original ordinance was adopted on August 7, 1989. The ordinance was amended on July 17, 2006 and January 8, 2018.

CHAPTER 11 - PUBLIC NUISANCES

11.02 OUTDOOR AND OPEN BURNING

(1) PURPOSE

This ordinance is intended to promote and safeguard the public health, safety and welfare of the citizens of the Town of Cottage Grove due to the air pollution and fire hazards of outdoor and open burning.

(2) DEFINITIONS

(a) "Air curtain destructor" means a solid waste disposal operation that combines a fixed wall open pit and a mechanical air supply, which uses an excess of oxygen and turbulence to accomplish the smokeless combustion of clean wood wastes and similar combustible materials.

(b) "Fire Pit" means an area cleared down to bare dirt and hollowed out at least six inches deep.

(c) "Fire Ring" means a barrier to keep the fire from escaping from a fire pit, such as stones, a tire rim, or commercially available fire ring at least 11 inches deep.

(d) "Campfire" means a small outdoor fire in a fire pit or surrounded by a fire ring, intended for recreation or cooking.

(e) "Outdoor Furnace" means a furnace, stove or boiler that is not located within a building intended for habitation by humans or domestic animals.

(f) "Fire Chief" means the Chief of the Cottage Grove Volunteer Fire Department.

(g) "Open burning" means combustion in which the by-products thereof are emitted directly into the ambient air, without passing through a stack or chimney, including the combustion occurring at a properly operated air curtain destructor. Open burning does not include the combustion which occurs in any enclosed or covered unit designed to prevent the escape of any burning materials.

(3) GENERAL PROHIBITION ON OPEN BURNING, OUTDOOR BURNING AND REFUSE BURNING.

Open burning, outdoor burning and refuse burning are prohibited in the Town limits unless the burning is specifically permitted by this ordinance.

(4) PROHIBITED OUTDOOR AND OPEN BURNING

(a) Open burning of any wet combustible rubbish, garbage, oily substances, asphalt, rubber or plastic products, or other materials prohibited by Wis. Admin. Code §§ NR 429.04 or 502.11.

(b) Burning of explosive or dangerous material without a permit issued by either the Wisconsin Department of Natural Resources (DNR), or the Wisconsin Department of Safety and Professional Services (WDSPS).

(c) Open burning in an air curtain destructor without first obtaining a permit from the DNR and having received written approval from the town board.

(d) Open burning of any material whatsoever by businesses, excluding agricultural or silvicultural facilities, except where a wood burning site license under Wis. Admin. Code NR § 502.11(f), has been approved by the WDNR.

(e) Open burning of any material whatsoever by agricultural or silvicultural facilities, except for stumps, trees, limbs, brush and weeds, as described in Wis. Admin. Code NR § 502.11(2)(a).

CHAPTER 11 - PUBLIC NUISANCES

TOWN OF COTTAGE GROVE - CODE OF ORDINANCES

(5) REGULATED OPEN BURNING

The following open burning activities are allowed, provided that the open burning is conducted by an individual with a valid Open Burning Permit and in compliance with all conditions set forth in the Open Burning Permit and in (6) through (8) below:

- (a) Open burning of trees, stumps, brush, dry leaves, plant clippings, weeds, and other dry combustible materials generated on the property, including that from clearing and maintenance of rights of way
- (b) Any non-enclosed or non-covered cooking fires or campfires.
- (c) Open burning, or fires set for practice and instruction of fire fighters, or testing of firefighting equipment.

(6) OPEN BURNING PERMITS

(a) DEFINITIONS

1. "Open Burning Permit" means a yearly permit for daytime burning of materials permitted under section (5). Once issued, the permit holder is required to call the fire department burn line or visit the fire department's web site to check for any burning restrictions prior to burning on the day of the burn.
2. "Campfire Permit" means a yearly permit for recreational or cooking fires in a fire pit or surrounded by a fire ring.

- (b) Open Burning Permits shall be required for all regulated open burning conducted within the limits of the Town, as described in (6).
- (c) Open Burning Permits shall be issued by the Town Chair or his/her designee.
- (d) Open Burning Permits shall not be required for any activity described in (5)(c), when these activities are conducted by the Cottage Grove Fire Department.
- (e) Open Burning Permits shall only be issued to an adult with a vested interest in the land described on the permit.
- (f) Open Burning Permits may be denied to any person found to be in violation of any provision of this ordinance for a period of up to one year from the date of the violation.
- (g) Open Burning Permits shall detail all conditions that apply to the activity being permitted, and a copy of the permit shall be available at the burning site. A current copy of the burning permits is attached as Appendix 11-A with the same force and effect as if it were fully reprinted herein.

(7) STANDARD OPEN BURNING PERMIT CONDITIONS

The following conditions shall apply to any Open Burning Permit issued by the Town:

- (a) A responsible adult with the physical and mental capacity to conduct any burning for which the Open Burning Permit is issued shall be in attendance at any fire until it is totally extinguished.
- (b) All open burning shall be conducted in a safe manner, when wind and weather conditions are such that they do not create any fire hazards to adjacent properties and the open burning can be safely controlled. Open burning may be restricted due to weather conditions at the discretion

CHAPTER 11 - PUBLIC NUISANCES

of the Fire Chief.

- (c) Except for campfires, or when specifically noted on the permit as a special condition, no open burning shall be conducted between sunset and sunrise.
- (d) Campfires shall be extinguished by 10:00 P.M. on Sunday thru Thursday and 11:00 P.M. on Friday or Saturday, or shall be extinguished immediately upon the request of a neighbor due to smoke causing a nuisance on the neighboring property.
- (e) No open burning shall be conducted within 20 feet from any structure, hay stack, or fuel storage location, or upon any surface within a right-of-way, public or private (except when burning is performed by Town or County staff in connection with clearing of the right-of-way).
- (f) Adequate firebreaks shall be provided, and arrangements shall be made to notify the fire department in case of an emergency (i.e.: having a phone available to DIAL 911).
- (g) The open burning shall not be in violation of any federal air control rules, or any state air pollution control rules that are required by applicable federal laws or regulations.

(8) OUTDOOR FURNACES

Subject to the other provisions of this ordinance and the terms of any permit issued under this ordinance, an outdoor furnace may be used in the Town only in accordance with the following provisions:

- (a) The outdoor furnace shall not be used to burn any of the prohibited materials listed in section (4) of this ordinance.
- (b) The outdoor furnace shall be located at least 250 feet from the nearest building which is not on the same property as the outdoor furnace unless written approval of the burning location is obtained from the owner of the nearest building that is not on the same property. A copy of the approval shall be provided to the Town Board prior to commencing burning.
- (c) The outdoor furnace shall have a chimney that extends at least 15 feet above the ground surface or higher. The Town Board may approve a lesser height on a case-by-case basis if necessary to comply with manufacturer recommendations and if the smoke from the lower chimney height does not create a nuisance for neighbors.
- (d) Outdoor furnace installations completed prior to January 8, 2010 will be considered grandfathered in for the purposes of (b) and (c) above.

(9) RIGHT OF ENTRY AND INSPECTION

(a) The Fire Chief or any authorized officer, agent, employee or representative of the Town who presents credentials may inspect any property for the purpose of ascertaining compliance with the provisions of this ordinance. Note: If the owner or occupant of the premises denies access to the property for this purpose, a special inspection warrant may be obtained in accordance with §§ 66.122 and 66.123 Wis. Stats. In the event of a fire emergency, the Fire Chief and members of the Fire Department may access property to extinguish uncontrolled fire in order to protect the safety of persons and property.

(10) PENALTY FOR VIOLATION

- (a) In addition to, and separate from, the possible liability referred to in (b) and (c), violations of this ordinance shall be punishable as Class D forfeitures, s. TCG § 25.04.
- (b) Any violation of this ordinance shall result in the permit being revoked, and the fire being extinguished.

CHAPTER 11 - PUBLIC NUISANCES

TOWN OF COTTAGE GROVE - CODE OF ORDINANCES

(c) The permit holder, or responsible party where a permit was not obtained, will be liable for any and all costs incurred by the Town in responding to and extinguishing any outdoor or open burning which is in violation of this ordinance, and any other liability resulting from damage caused by the fire.

(11) EFFECTIVE DATE

(a) Original ordinance adopted May 21, 2001

(b) Amended January 4, 201, January 6, 2014 and January 20, 2020

(c) This section shall take effect upon passage and posting and/or publication (if required).

11.03 FENCING OF HAZARDOUS AREAS

(1) DEFINITIONS

(a) "Fence" means a fixed barrier which shall not be less than four feet in height, and shall be constructed of welded wire, or similar materials which would provide similar strength; and shall have openings no greater than that found in a woven wire fence that met the specifications of the Wisconsin department of transportation (DOT) for right-of-way fencing. A current copy of DOT standard detail drawing 15 B 1 is attached as Appendix 11-B, with the same force and effect as if it were fully reprinted herein.

(b) "Gate" means a rigid, movable barrier which shall not be less than 4 feet in height; and shall be constructed of sturdy materials which would provide similar strength and design as that found in an agricultural pipe gate.

(c) "Hazardous area" means any area whose natural topography has been altered by the activities of the landowner, lessee, tenant, or other person, either now or prior to the effective date of this ordinance, such that; a slope of 2 to 1 or less, exists a distance of at least ten feet along the top of the slope; and the overall height of the slope is more than eight feet.

(2) FENCING REQUIREMENTS

(a) All landowners, or any person who has created a hazardous area on any land within the Town, shall fence the hazardous area within 30 days from the effective date of this ordinance. The fence shall be posted with "warning" signs that meet, or exceed, the sign specifications under § 943.13(2)(am) Wis. Stats.

(b) All fencing shall be erected and maintained no less than ten feet from the top edge of a slope described in (1)(c); and be of sufficient length and contour to effectively obstruct access to the hazardous area, along the top edge of the slope.

(c) A gate shall be erected across all access roads, which shall be kept closed and locked with a padlock, or similar device, whenever there is no authorized activity being conducted on the site.

(d) In addition to the requirements of this ordinance, all applicable regulations of the Wisconsin Department of Industry, Labor and Human Relations (DILHR); the Wisconsin Department of Natural Resources (WDNR); and the U.S. Department of Labor, Mine Safety and Health Administration (MSHA), are hereby adopted and made a part of this ordinance with the same force and effect as if they were fully reprinted herein, and shall be complied with by the person described in (a).

(3) PENALTY FOR VIOLATION

CHAPTER 11 - PUBLIC NUISANCES

In addition to, and separate from, the possible liability from a failure to comply with any DILHR, WDNR, or MSHA regulation; violations of this ordinance shall be punishable as class B forfeitures, under s. TCG § 25.04.

(4) EFFECTIVE DATE

- (a) The original ordinance was adopted on June 7, 1993.
- (b) This section shall take effect upon passage and publication.

11.04 REGULATION OF MASSAGE ESTABLISHMENTS AND TECHNICIANS

(1) DEFINITIONS

- (a) "Massage" means a rubbing, kneading, etc., of a part of the body of one person, by another; by any means, physical or mechanical.
- (b) "Massage establishment" means a place of business, not otherwise regulated under Ch. 448 Wis. Stats., where a massage is made available for a consideration.
- (c) "Massage technician" means any person, not otherwise regulated under Ch. 448 Wis. Stats., who administers a massage for a consideration; whether or not they are employed in a massage establishment.
- (d) "Operator" means any person licensed by the Town Board to operate a massage establishment.
- (e) "Patron" means any person who receives a massage from a massage technician, under any circumstances.

(2) LICENSE REQUIREMENTS

- (a) No person shall operate a massage establishment, or act as a massage technician within the town limits, until such time as a license is issued for that activity from the town. Application shall be made to the Town Clerk; using a form developed and approved by the Town Board.
- (b) All licensed premises shall have an operating, toll free telephone within the premises, to summon help in an emergency.

(3) FEES

- (a) A fee, as specified in s. TCG § 07.02(11), shall accompany each application for a massage establishment, massage technician, and operator's license. The fee for each of these licenses shall be specified on the application, and shall be paid to the town treasurer in US currency, money order or check payable to: the Town of Cottage Grove. An itemized receipt shall be provided for all currency received.
- (b) Each license shall have its own fee structure. Any person required to hold more than one license, shall pay the appropriate fee for each.

(4) LICENSING PERIOD

All massage establishment, massage technician, and operator's licenses issued shall be valid from July 1 of one year, to June 30 of the following year.

(5) ISSUANCE PROCEDURE

- (a) The Town Clerk shall provide, at no cost, one copy of this ordinance and the appropriate town application forms to all persons applying for a massage establishment, massage technician, or operator's license.

CHAPTER 11 - PUBLIC NUISANCES

TOWN OF COTTAGE GROVE - CODE OF ORDINANCES

- (b) The Town Board shall review all applications received by the Town Clerk, and shall schedule a public hearing to hear any community concerns, prior to acting on any application.
- (c) No license shall be issued to any premises for which taxes, assessments, or other claims of the town are delinquent and unpaid; or to any person delinquent in payment of such claims.
- (d) No license shall be issued to any person who has an arrest and conviction record which, in the opinion of the Town Board, disqualifies them from holding such license.
- (e) No massage technician license, shall be issued to any person who has not submitted a certificate from a licensed physician that the applicant has had a complete physical examination, including blood screens within the past 30 days; and that the examining physician has found the applicant to be free of communicable diseases.

(6) PENALTY FOR VIOLATION

In addition to, and separate from, any penalties set forth in state statutes, and county ordinances; violations of this ordinance shall be punishable as Class B forfeitures, under s. TCG § 25.04.

(7) EFFECTIVE DATE

- (a) The original ordinance was adopted March 3, 1975.
- (b) This section shall take effect upon passage and publication.

11.05 CONTROL OF NOXIOUS AND NUISANCE WEEDS

(1) DEFINITIONS

- (a) "Noxious weeds" means the following: Canada thistle, leafy spurge, field bindweed (creeping Jenny), cannabis (marijuana/hemp), and any other such weeds as may be specified in § 66.0407(1)(b), Stats.
- (b) "Nuisance weeds" means any non-native member of the genus *Lythrum* (purple loosestrife) or hybrids thereof, and multiflora rose; along with any other weeds allowed to grow to such a height and density, that would interfere with the sight distance at a highway intersection, or would otherwise create a public nuisance, as defined in s. TCG § 11.06(1).
- (c) "Weed Commissioner" means the person designated by the Town Chair, under § 66.0517 Wis. Stats.; having the duties and powers specified in (2)(c) and (2)(d), and § 66.0517 Wis. Stats.

(2) WEED COMMISSIONER

- (a) The Weed Commissioner shall be appointed annually by the Town Chair on or before May 15; and shall have the duties and powers specified in § 66.0517 Wis. Stats., in addition to those specified in (c) and (d) below.
- (b) At the same time the Weed Commissioner is appointed; a class 2 notice shall be published specifying that every person that owns, occupies, or controls lands within the town limits is required by law to destroy all noxious weeds, as described in (1)(a); and that all nuisance weeds shall be controlled, as specified by the Weed Commissioner.
- (c) The Weed Commissioner shall review any claim that a growth of nuisance weeds has become a public nuisance, and shall take action to ensure that the nuisance is abated. The control of nuisance weeds, shall follow the procedure for the destruction of noxious weeds, described in § 66.0517 Wis. Stats.

CHAPTER 11 - PUBLIC NUISANCES

(d) The Weed Commissioner may request the Highway Superintendent to use Town-owned mowing equipment to control the growth of nuisance weeds, if such use is determined to be the most economical method available; or when the landowner of the parcel cannot be contacted as described in (b).

(3) PENALTY FOR VIOLATION

In addition to, and separate from, any penalty specified in any applicable state statute; violations of this ordinance shall be punishable as Class D forfeitures, under s. TCG § 25.04.

(4) EFFECTIVE DATE

This section shall take effect upon passage and publication.

11.06 PUBLIC NUISANCES

(1) DEFINITIONS

(a) "Authorized agent" means employees or designees of the Town of Cottage Grove authorized to administer or enforce this Chapter, including but not limited to law enforcement officers, Building Inspectors, Fire Inspectors, the Highway Superintendent or Weed Commissioner.

(b) "Public nuisance" means any thing, act, occupation, condition or use of property, which continues for such length of time, as to:

1. Substantially annoy, injure or endanger the comfort, health, repose, or safety of the public.
2. In any way render the public insecure in life, or the use of property.
3. Offend the public morals, or the community's standards of decency.
4. Unlawfully, and substantially interfere with, obstruct or tend to obstruct, or render dangerous for passage, any highway, navigable body of water, other public way or property.
5. Generate loud, discordant, and unnecessary noises, or vibrations of any kind; including, but not limited to, sound levels in excess of those specified in Table G-16 of the OSHA General Industry Standards [29 C.F.R. § 1910.95]. A copy of the current Table G-16 is attached as Appendix 11-C, with the same force and effect as if it were fully reprinted herein.

(c) "Public nuisances affecting health" include, but are not limited to, the following:

1. All decayed, harmfully adulterated, or unwholesome food or drink, sold or offered for sale to the public.
2. Carcasses of animals, birds, or fowl not intended and processed for human consumption which are not buried or otherwise disposed of in a sanitary manner, within 24 hours after death.
3. Accumulations of stagnant water within a platted subdivision; in which mosquitoes, flies, or other insects can be expected to breed. Approved retention ponds on public property are exempt from this section.
4. Air emissions in excess of levels permitted by the Wisconsin Department of Natural Resources (DNR).

CHAPTER 11 - PUBLIC NUISANCES

TOWN OF COTTAGE GROVE - CODE OF ORDINANCES

5. The pollution of any waters of the state, in violation of any DNR regulation.
6. Any use of property, substances, or things within the town limits, emitting any offensive or noxious odor or effluent; which is found to discomfort, annoy, or inconvenience an appreciable number of town residents. All wells, septic tanks, grease traps, cisterns, privy vaults, and day wells not covered or otherwise secured to prevent unauthorized access.

(d) "Public nuisances affecting community morals" include, but are not limited to the following:

1. All lewd acts conducted while in view of the public; whether or not the party involved was in a private residence.
2. All bawdy houses, and any building or structure maintained for the purposes of gambling, prostitution or promiscuous sexual activity.
3. Any place classified as an alcohol beverage establishment, under Ch.125 Wis. Stats. and TCG Ch. 05; that does not have a valid license issued by the town.
4. Any place where town ordinances, or state statutes, are openly, repeatedly, and intentionally violated.

(e) "Public nuisances affecting safety" include, but are not limited to, the following:

1. All signs, awnings, and similar structures, over or adjacent to, parks and other public areas, situated such that they endanger the public.
2. All trees, hedges, signs, or other obstructions adjacent to a highway, which limit the sight distance of any person approaching an intersection.
3. All tree limbs, branches, and other non-conductive obstructions over any highway within the Town limits; less than 14 feet above the paved surface of the highway.
4. All wires, cables, and other conductive obstructions over any highway within the Town limits; less than 18 feet above the paved surface of the highway.
5. All trees which fall in whole, or in part, into the highway right-of way or onto any other public lands.
6. All refrigerators, or other containers with air-tight doors, which are located outside of a residence or other secured structure; which have not had all the doors removed, or are not equipped with a device for opening the door from the inside.

(2) REGULATION OF PUBLIC NUISANCES

(a) No person shall create, or maintain, any public nuisance, as described in (1)(b)-(1)(e), within the Town limits.

(b) All sound level monitoring shall be conducted at the property line of the parcel upon which the sound is generated; or at any alternate location determined to be appropriate. All noise levels shall be measured on the A scale of a standard sound level meter at slow response.

(c) Any person in violation of (a) shall be subject to the enforcement procedures set forth in s. TCG §11.10.

(3) EFFECTIVE DATE

CHAPTER 11 - PUBLIC NUISANCES

- (a) The original ordinance was adopted on March 11, 1994 and amended on December 15, 2008 and January 8, 2018.
- (b) This section shall take effect upon passage and publication.

11.07 REGULATION OF PEDDLERS AND TRANSIENT MERCHANTS.

(1) REGISTRATION REQUIRED.

It shall be unlawful for any transient merchant to engage in sales within the Town limits without being registered for that purpose as provided herein.

(2) DEFINITIONS

- (a) "Transient merchant" means any individual who engages in the retail sale of merchandise at any place in the Town temporarily, and who does not intend to become and does not become a permanent merchant of such place. For purposes of this section, sale of merchandise includes a sale in which the personal services rendered upon or in connection with the merchandise constitutes the greatest part of value for the price received, but does not include a farm auction sale conducted by or for a resident farmer of personal property used on the farm, or the sale of produce or other perishable products at retail or wholesale by a resident of this state.
- (b) "Permanent merchant" means any person who, for at least six months (i) has continuously operated an established place of business in the local trade area among the communities bordering the place of sale or (ii) has continuously resided in the local trade area among the communities bordering the place of sale and now does business from her/his residence.
- (c) "Merchandise" shall include personal property of any kind, and shall include merchandise, goods, or materials provided incidental to services offered or sold. The sale of merchandise includes donations required by the seller for the retention of goods by a donor or prospective customer.
- (d) "Charitable organization" shall include any benevolent, philanthropic, patriotic, or eleemosynary person, partnership, association or corporation, or one purporting to be such.
- (e) "Clerk" means the Town Clerk.
- (f) "Sales" means solicitation for purchase of services, good or combination thereof.

(3) EXEMPTIONS.

The following shall be exempt from all provisions of this ordinance.

- (a) Any person delivering newspapers, fuel, dairy products or bakery goods to regular customers on established routes;
- (b) Any person selling merchandise at wholesale to dealers or retailers in such merchandise;
- (c) Any person selling agricultural products which that person has grown;
- (d) Any person who has an established place of business where the merchandise being sold is offered for sale on a regular basis, and in which the buyer has initiated contact with, and specifically requested, a home visit by said person;
- (e) Any permanent merchant or employee thereof who takes orders at the home of the buyer for merchandise regularly offered for sale by such merchant within this county and who delivers such merchandise in their regular course of business;
- (f) Any person holding a sale required by statute or by order of any court and any person

CHAPTER 11 - PUBLIC NUISANCES

TOWN OF COTTAGE GROVE - CODE OF ORDINANCES

conducting a bona fide auction sale pursuant to law;

- (g) Governmental agents and employees in the performance of their official duties
- (h) Any employee, officer or agent of a charitable organization who engages in direct sales for or on behalf of said organization, provided that there is submitted to the clerk proof that such charitable organization is registered under § 440.42 Wis. Stats. Any charitable organization engaging in the sale of merchandise and not registered under § 440.42 Wis. Stats., shall be required to register under this ordinance;
- (i) This ordinance does not apply to transient merchants while doing business at special events or under other licenses authorized by the Town Board.

(4) REGISTRATION.

(a) Applicants for registration must complete and return to the Town Clerk a registration form which shall require the following information:

1. name, permanent address and telephone number, and temporary address, if any;
2. age, height, weight, color of hair and eyes, and sex;
3. name, address and telephone number of the person, firm, association or corporation that the transient merchant represents or is employed by, or whose merchandise is being sold;
4. temporary address and telephone number from which business will be conducted, if any;
5. nature of business to be conducted and a brief description of the merchandise, and any services offered;
6. proposed methods of delivery of merchandise, if applicable;
7. make, model and license number of any vehicle to be used by applicant in the conduct of her/his business;
8. most recent cities, villages, towns, not to exceed three, where applicant conducted her/his business;
9. place where applicant can be contacted for at least seven days after leaving the Town;
10. statement as to whether applicant has been convicted of any crime or ordinance violation related to applicant's transient merchant business within the last five years, and the nature of the offense and the place of conviction.

(b) Applicants shall present to the Town Clerk for examination:

1. a driver's license or some other proof of identity as may be reasonably required;
2. a state certificate of examination and approval from the sealer of weights and measures where applicant's business requires use of weighing and measuring devices approved by state authorities;
3. a state health officer's certificate where applicant's business involves the handling of food or clothing and is required to be certified under state law; such certificate to state

that applicant is apparently free from any contagious or infectious disease, dated not more than ninety (90) days prior to the date the application license is made.

(c) At the time of license registration, a fee shall be paid to the clerk to cover the cost of processing said registration. The registration fee shall be set by resolution of the Town Board.

(d) Upon payment of said fee and satisfactory completion of the investigation under section (5) below, the clerk shall register the applicant as a transient merchant and date the entry. Said registration shall be valid for a period of one year from the date of entry, unless revoked as provided below.

(e) Any person refused or denied registration may appeal the denial to the Town Board, which shall follow the procedure set forth under section (7) below.

(5) INVESTIGATION.

(a) Upon receipt of each application, the Town Clerk may refer it immediately to the Dane County Sheriff's Department, which may make and complete an investigation of the statements made in such registration.

(b) The Town Clerk shall refuse to register the applicant if it is determined, pursuant to the investigation above, that: the application contains any material omission or materially inaccurate statement; complaints of a material nature have been made against the applicant by authorities in the most recent cities, villages and towns, in which the applicant conducted similar business; the applicant was convicted of a crime, statutory violation or ordinance violation within the last five (5) years, the nature of which is directly related to the applicant's fitness to engage in direct selling; or the applicant failed to comply with any applicable provision of section (4) above.

(c) The Dane County Sheriff, or designee, shall report to the Town Clerk any charges or convictions under this ordinance and the Town Clerk shall note any such violation on the record of the transient merchant.

(6) REGULATION OF TRANSIENT MERCHANTS.

(a) Prohibited Practices.

1. A transient merchant shall not: call at any dwelling or other place between the hours of 9:00 P.M. and 9:00 A.M. except by appointment; call at any dwelling or other place where a sign is displayed bearing the words "No Peddlers," "No Solicitors" or words of similar meaning; call at the rear door of any dwelling place; or remain on any premises after being asked to leave by the owner, occupant or other person having authority over such premises.
2. A transient merchant shall not misrepresent or make false, deceptive or misleading statements concerning the quality, quantity, or characteristics of any merchandise offered for sale, the purpose of her/his visit, her/his identity or the identity of the organization she/he represents. If requested, a charitable organization transient merchant shall specifically disclose what portion of the sale price of the merchandise being offered will actually be used for the charitable purpose for which the organization is soliciting. Said portion shall be expressed as a percentage of the sale price of the merchandise.
3. No transient merchant shall by his or her activities impede the free use of sidewalks and streets by pedestrians and vehicles. Where sales are made from vehicles, all traffic and parking regulations shall be observed.

CHAPTER 11 - PUBLIC NUISANCES

TOWN OF COTTAGE GROVE - CODE OF ORDINANCES

4. No transient merchant shall make any loud noises or use any sound amplifying device to attract customers if the noise produced is capable of being plainly heard outside a one-hundred-foot radius of the source.
5. No transient merchant shall allow rubbish or litter to accumulate in or around the area in which she/he is conducting business.

(b) Disclosure Requirements.

1. During all transactions, a transient merchant shall expressly disclose his/her name, the name of the company or organization he/she is affiliated with, if any, and the identity of merchandise or services he/she offers to sell.
2. The transient merchant shall comply with all consumer protections laws, including but not limited to the requirements for consumer approval transactions under Chapter 423 of the Wisconsin Statutes, as may be amended.
3. If the transient merchant takes a sales order for the later delivery of merchandise, he/she shall, at the time the order is taken, provide the buyer with a written statement containing the terms of the agreement, the amount paid in advance whether full, partial, or no advance payment is made, the name, address and telephone number of the seller, the delivery or performance date, and whether a guarantee or warranty is provided and, if so, the terms thereof.

(7) REVOCATION OF REGISTRATION.

(a) Registration may be revoked by the Town Board after notice and hearing, if the registrant made any material omission or materially inaccurate statements in the application for registration, made any fraudulent, false, deceptive or misleading statement or representation in the course of engaging in transient sales, violated any provision of this Ordinance or was convicted of any crime or ordinance or statutory violation which is directly related to the registrant's fitness to engage in selling. A signed statement or complaint setting forth the request and/or basis for license revocation may be made by the Town Clerk, Dane County Sheriff or other Town resident.

(b) Written notice of the hearing shall be served personally or via U.S. Mail to the transient merchant's permanent address at least seventy-two (72) hours prior to the time set for the hearing. Such notice shall contain the time and place of hearing and a statement of the acts upon which the hearing will be based. The hearing shall be in front of the Town Board. The complainant and transient merchant may present and cross examine witnesses, and present other information to the Town Board.

(8) PENALTY.

The penalty for violation of this Ordinance as provided in s. TCG § 25.04 shall be a Class of "B" forfeiture.

(9) SEVERANCE CLAUSE.

The provisions of this ordinance are declared to be severable, and if any section, sentence, clause or phrase of this ordinance shall for any reason be held to be invalid or unconstitutional, such decision shall not affect the validity of the remaining sections, sentences, clauses and phrases of this ordinance; they shall remain in effect, it being the legislative intent that this ordinance shall stand notwithstanding the invalidity of any part.

CHAPTER 11 - PUBLIC NUISANCES

(10) EFFECTIVE DATE.

This ordinance shall take effect upon passage and publication.

11.08 FALSE ALARMS PROHIBITED

(1) DEFINITIONS

(a) “False Signal” means any signal which is emitted by an intrusion, fire, holdup or other alarm system which is not the result of an intrusion by persons, a fire, or a holdup. A signal is emitted for the purposes of this ordinance when it is directly transmitted to a Law Enforcement Department or Fire Department or transmitted to any person who subsequently reports such signal to a Law Enforcement Department or Fire Department.

(b) “Owner” means the person or legal entity that owns the property from which the false signal is emitted, except that, if the premises are leased or rented, the lessee or occupant of the property or part thereof from which the false signal is emitted shall be deemed the owner.

(2) FALSE ALARMS PROHIBITED

No person shall permit an intrusion, fire, holdup alarm or any other alarm system to repeatedly emit false signals.

(3) RESPONSIBILITY FOR OPERATION OF ALARM SYSTEMS.

(a) Upon a finding that a signal from an alarm system is a false signal, the Law Enforcement Department shall notify the building owner of the false signal. It shall then be the responsibility of the owner to secure the building and prevent additional false signals. A second or subsequent false alarm within a twelve-hour period shall constitute a violation of this ordinance and the building owner shall be liable for such violation.

(b) No building owner shall permit an alarm system to emit more than three false signals during any sixty-day period. A fourth false signal during a sixty-day period shall constitute a violation of this ordinance and the building owner shall be liable for such violation.

(4) PENALTY FOR VIOLATION

Any violation of this ordinance shall be subject to a Class C forfeiture as specified in s. TCG § 25.04(1)(b). Each and every day such violation thereafter shall be considered a separate offense.

(5) EFFECTIVE DATE

(a) The original ordinance was adopted November 17, 2008

(b) This section shall take effect upon passage and publication.

11.09 PROPERTY MAINTENANCE

(1) PURPOSE.

(a) The general purpose of this Ordinance is to protect and enhance the public health, safety, and general welfare of the residents of the Town by establishing minimum standards for maintenance of premises.

(B) To further its general purpose, this Ordinance has the following objective: To provide a means to declare that certain land, buildings and structures are detrimental to the health, safety and general welfare of the residents of this community, and require that the community standards set forth in this Ordinance be enforced.

(2) APPLICABILITY.

CHAPTER 11 - PUBLIC NUISANCES

TOWN OF COTTAGE GROVE - CODE OF ORDINANCES

This Ordinance shall apply to all land, buildings, and structures (sometimes referred to collectively herein as “premises”) in the Town, without regard to its class or its date of construction, alteration, or repair.

(3) INTERPRETATION.

This Ordinance is not intended to replace or modify standards otherwise established for the construction, replacement or repair of buildings and structures. However, in the event there is any inconsistency or conflict between the provisions of this Ordinance and any other existing Town Ordinance, the more restrictive provisions shall apply.

(4) DEFINITIONS.

(a) Owner. Any person who alone, jointly, or severally with others, shall hold title to premises, or who shall be in actual possession of, or have charge, care or control of premises as an employee or agent of the title holder, or who shall be trustee or guardian of the estate or person of the title holder. For purposes of providing notice under this Ordinance, the Town may rely on the presumption that the owner is the person or persons designated on the tax roll with respect to the premises.

(b) Occupant. Any person occupying or having use of premises or any part thereof.

(c) Operator. Operators shall mean any person who has apparent authority for charge, care or control of premises or any part thereof.

(5) COMPLIANCE IS RESPONSIBILITY OF OWNERS AND OCCUPANTS.

Each owner and occupant of the premises shall have an independent responsibility for compliance. All owners and occupants shall be jointly and severally responsible for performance of the duties and obligations prescribed in this Ordinance. No owner or occupant shall be relieved from any such duty or obligation because another person is also responsible for performance of such duty or obligation. No owner or occupant shall be relieved from liability under this Ordinance because said person has contracted said responsibility to an operator or other person.

(6) PROPERTY MAINTENANCE RESPONSIBILITIES OF OWNERS, OPERATORS AND OCCUPANTS.

Every owner, operator and occupant who has assumed responsibility for maintaining the property pursuant to a written lease shall improve and maintain all property under his or her control so as to comply with the following minimum requirements:

(a) All exterior areas of the property shall be graded to divert water away from all buildings.

(b) The interior of all vacant buildings and structures and all exterior areas of all property shall be maintained in a safe and sanitary condition, free from accumulation of debris, rubbish, garbage, physical hazards, rodent and varmint harborages and infestations, and animal feces. All animal feces shall be removed within 24 hours.

(c) Fences, structures, walks, driveways, parking areas and similar paved areas shall be properly maintained in a safe condition.

(d) The exterior surfaces of all buildings and structures not inherently resistant to or chemically treated to prevent deterioration shall be treated with a protective coating of paint or other suitable preservative which will provide adequate resistance to weathering.

CHAPTER 11 - PUBLIC NUISANCES

- (e) Every interior floor, wall and ceiling including door and window assemblies shall be kept in good repair and shall be capable of affording privacy from public view.
- (f) Every inside and outside stair, porch, platform, balcony and appurtenance thereto shall be maintained in good repair, safe to use and capable of supporting the load that normal use may cause to be placed thereon.
- (g) Every plumbing fixture and water and waste pipe shall be maintained in good repair and free from defects, leaks and obstructions.
- (h) Every water closet compartment floor surface and bathroom floor surface shall be maintained so as to be reasonably impervious to water and so as to permit such floor to be easily kept in a sanitary condition.
- (i) No owner shall allow an accumulation of rocks, trees, stumps, waste building material or other debris on the property; except such debris resulting from land development, building construction, street grading, or installation of underground utilities may remain on the property for a period of not more than 10 days, unless a valid building permit has been issued, in which case such accumulation be disposed of as set forth in the building permit.
- (j) All private storm sewers and building storm sewers shall be properly installed and maintained in good repair, free from defects, leaks and obstructions.
- (k) All rain gutters, downspouts, including extensions, and the discharge systems for sump pumps shall be maintained in good repair and shall minimize the effect of runoff onto adjacent properties.
- (l) All structures shall be constructed and maintained so that the exterior is reasonably weathertight and inaccessible to rodents, vermin and insects.
- (m) The exterior of all property shall be maintained in a reasonably litter-free condition. All litter that is subject to movement by the elements shall be promptly removed so as to reasonably prevent it being blown onto other property by the elements.

(7) PAVED DRIVEWAYS.

All driveways on properties in a platted residential subdivision shall be paved with concrete, asphalt, brick, pervious paver or a similar surface within one year of:

- (a) Construction;
- (b) Remodeling or expansion of the garage so as to require a building permit; or
- (c) Expansion of the driveway.

(8) VACANT AND DAMAGED BUILDINGS.

- (a) Vacant buildings.

Requirement to secure vacant buildings. Any building which is vacant and unsecured for any reason constitutes a public nuisance. No owner, operator or occupant may maintain or permit a public nuisance within the Town. The owner shall abate the nuisance by securing the building, including any shed or outbuilding, against entry by persons or animals. This may include, with prior written approval of the Town Clerk or Building Inspector, adequately boarding up doors, windows and other openings in a workmanlike manner so as to prevent entry, vandalism or damage. Trespassers, garbage, animals, animal nests and animal nesting materials shall be removed prior to securing the building.

CHAPTER 11 - PUBLIC NUISANCES

TOWN OF COTTAGE GROVE - CODE OF ORDINANCES

(b) Other requirements. The owner of a vacant building shall ensure that the following requirements are met with respect to the vacant building:

1. The utilities, plumbing, electrical and heating systems shall be maintained at all times in a safe condition, inactivated or drained so as to prevent the possibility of damage to the structure by the failure of such utilities and so as to prevent hazardous and dangerous conditions.
2. At least one door boarded at the grade level shall be maintained with locks and hinges to permit entry for inspection purposes.
3. Access to the building for inspection purposes is required to be provided to the Town Clerk or Building Inspector.
4. Screening or alternate methods of boarding may be permitted upon prior written approval by the Town Clerk or Building Inspector.
5. The Town Clerk or Building Inspector shall be notified in writing no later than 10 days prior to the sale, transfer of possession, or the unboarding of the property.

(c) Damaged buildings. When any building has been damaged by fire or other cause, such that hazardous or dangerous conditions exist, and the building cannot be secured by conventional locking or boarding up of windows and doors, such building shall be fenced off so as to prevent access and entry to the structure and the area immediately surrounding the structure.

(9) OUTDOOR STORAGE.

No owner, operator or occupant of property in a residential district shall store or accumulate outdoors on such property any of the following items unless such property is expressly zoned to permit such storage or accumulation:

(a) Vehicles. No owner, operator or occupant shall store outdoors any vehicle in the street yard (the yard upon which the fire number is affixed) of any property in any residential district, except as follows:

1. The number of vehicles in the street yard does not exceed the following number:
 - a. For properties on which three or more dwelling units exist, the number of vehicles shall not exceed the number of parking spaces provided on the site.
 - b. For purposes of this subsection, one or two vehicles on a single trailer designed for the transportation of those vehicles shall be considered one vehicle.
2. All such vehicle(s) shall comply with all of the following:
 - a. They are parked with all points of contact on a surface preventing the item(s) from sinking into the ground, with no part extending over a public sidewalk or public street.
 - b. They are owned by and lawfully registered to at least one of the residents of the dwelling unit, with the exception of temporary guests staying at the dwelling unit.
 - c. They shall not remain at that location without being moved for no longer than nine consecutive months.

CHAPTER 11 - PUBLIC NUISANCES

- d. They are lawfully licensed and properly display license plates and current registration.
 - e. They are in operating condition, except vehicles which are actively being repaired.
 - f. They are not used for dwelling purposes, except for overnight sleeping for a maximum of 14 days in any one calendar year.
 - g. They are not connected to sewer lines, waterlines, except temporary electrical connections for charging batteries.
 - h. They are not used to store goods, materials or equipment other than those items considered to be part of the unit or essential for its immediate use.
3. Except as provided in subsection 1.a or 1.b above, all vehicles shall be stored inside a garage or outside in the back yard or side yard of the property. Vehicles may be stored on the side yard of a property and shall be parked with all points of contact on a surface preventing the item(s) from sinking into the ground, with no part extending over a public sidewalk or a public street.
 4. Notwithstanding any other provision in this subsection, no owner, operator or occupant of property in a residential district shall park or store outdoors on such property any semitractor or semitrailer for a period longer than 24 consecutive hours.
- (b) Nonvehicular items. No owner, operator or occupant shall store outdoors any nonvehicular personal property in the street yard of any property in a residential district for a period longer than seven days, except as follows:

1. Items may be stored in not more than two storage containers, each no greater than 75 gallons in size, which possess four complete sides and a lid, all of which are opaque.
2. Items may be placed within a closed and locked temporary storage container (commonly referred to as a "POD®") located on the driveway of the dwelling unit and which does not encroach on the sidewalk or public street. No such storage container shall be located on a property for more than 90 days in any twelve-month period.
3. Equipment and construction material necessary for construction being performed upon the property may be stored on the property for the duration of a building permit issued by the Town, if one is issued, otherwise for a period not to exceed 60 days.
4. All construction debris and trash shall be placed within a dumpster or other suitable container. Only one such dumpster or container shall be located on the property at one time and shall be promptly removed upon completion of the construction or renovation project, but in no case longer than 90 days, unless extended by the Town Clerk or Building Inspector for good cause.

(10) **MAINTENANCE AND APPEARANCE OF LAND.**

Lawn, hedges, bushes and plantings shall be kept trimmed and shall not be allowed to become overgrown and unsightly or allowed to obstruct pedestrians' or vehicles' view.

(11) **ADMINISTRATIVE PROVISIONS.**

(a) The Town Building Inspector is hereby made responsible for the enforcement of this Ordinance. All inspections, enforcement, orders or matters relating to violations of this Ordinance

CHAPTER 11 - PUBLIC NUISANCES

TOWN OF COTTAGE GROVE - CODE OF ORDINANCES

shall be under their direction and supervision. The Town Chairperson may authorize other public officials or employees of the Town to perform duties as they deem necessary to the enforcement.

(b) Town residents may register complaints of violations of this Ordinance to the Town Clerk, in writing, in person, by email or by telephone.

(c) The Town Building Inspector shall be supplied with official identification and shall exhibit such identification to the owner, operator or occupant upon request.

(d) Any person in violation of any provision of this Ordinance shall be subject to the enforcement procedures set forth in s. TCG § 11.10.

(12) EFFECTIVE DATE.

The original ordinance was adopted on May 7, 2012 and amended on January 8, 2018.

This section shall take effect upon passage and publication.

11.10 ENFORCEMENT AND PENALTIES

Any property owner or other individual found to be in violation of any provision of TCG Chapter 11 is subject to the following enforcement procedure and penalties:

(1) PLACARD ON BUILDING.

(a) If the Town Building Inspector determines that the building, structure, or premises are unsanitary, unsafe, or unfit for human habitation, the Town Building Inspector or a law enforcement officer shall post a placard on the premises containing the following notice: "This Building May Not Be Used For Human Habitation, Occupancy or Use." Thereafter, no person shall use the building, structure or premises for human habitation, occupancy or use until necessary repairs have been made.

(b) No person shall deface or remove the above described notice from any building, structure or premise until removal of such placard is authorized by the Town Building Inspector.

(2) NONCOMPLIANCE – REMEDY OF DEFECTS; ABATEMENT.

(a) Summary abatement.

1. Notice to owner. If the Town Building Inspector determines that a public nuisance exists within the Town and that there is a great and immediate danger to the public health, safety, peace, morals or decency, he or she shall immediately report such determination to the Town Chairperson, and may serve notice on the person causing, permitting or maintaining such nuisance or upon the owner or occupant of the premises where such nuisance is caused, permitted or maintained and to post a copy of said notice on the premises. Notice may be served by the Town Building Inspector or a Dane County Sheriff's deputy on the person causing, maintaining or permitting such nuisance or on the owner or occupant of the premises where such nuisance is caused, maintained or permitted, and a copy of such notice shall be posted on the premises. Such notice shall direct the person causing, maintaining or permitting such nuisance or the owner or occupant of the premises to abate or remove such nuisance within a period not less than 24 hours or greater than seven days and shall state that, unless such nuisance is so abated, the Town will cause the same to be abated and will charge the cost thereof to the owner, occupant or person causing, maintaining or permitting the nuisance, as the case may be.

CHAPTER 11 - PUBLIC NUISANCES

2. Abatement by the Town. If the nuisance is not abated within the time provided or if the owner, occupant or person causing the nuisance cannot be found, the Town Building Inspector shall cause the abatement or removal of such public nuisance.
- (b) Nonsummary abatement.
1. Order to abate nuisance. If the Town Building Inspector determines that a public nuisance exists on private premises but that the nature of such nuisance is not such as to threaten imminent danger to the public health, safety, peace, morals or decency, he/she shall issue an order reciting the existence of a public nuisance and requiring the owner or occupant of the premises to remove or abate the condition described in the order within the time period specified therein. The order shall be served personally on the owner of the building as well as the occupant, if different from the owner and applicable to the described nuisance, or at the option of the Town Building Inspector, the notice may be mailed to the last known address of the person to be served by registered mail with return receipt. If the owner or the occupant cannot be served, the order may be served by posting it on the main entrance of the premises and by publishing as a class 3 notice under Ch. 985, Wis. Stats. The time limit specified in the order runs from the date of service or publication.
 2. Abatement by the Town. If the owner or occupant fails or refuses to comply within the time period prescribed, the Town Building Inspector shall enter upon the premises and cause the nuisance to be removed or abated, and the Town shall recover the expenses incurred thereby from the owner or occupant of the premises or from the person who has caused or permitted the nuisance.
 3. Remedy from order. Any person affected by such order shall, within 30 days of service or publication of the order, apply to the circuit court for an order restraining the Town and the Town Building Inspector from entering on the premises and abating or removing the nuisance or be forever barred. The court shall determine the reasonableness of the order for abatement of the nuisance.
- (c) Other methods not excluded. Nothing in this section shall be construed as prohibiting the abatement of public nuisances by the Town or its officials in accordance with the laws of the State of Wisconsin or under any other provision of this Code applicable to a particular type of nuisance. No action taken to abate a nuisance shall preclude an action seeking a forfeiture as provided in s. TCG § 25.04. An action may be commenced by citation issued by the Town Building Inspector or Dane County Sheriff's Department.
- (d) Court order. Except where necessary under subsection (b), no officer hereunder shall use force to obtain access to private premises to abate a public nuisance, but shall request permission to enter upon private premises if such premises are occupied and, if such permission is denied, shall apply to any court having jurisdiction for an order assisting the abatement of the public nuisance.
- (3) PENALTIES.
- (a) A violation of any provision of TCG Chapter 11 shall be punishable as a Class D forfeiture under s. TCG § 25.04, plus reasonable costs of inspection and prosecution.
 - (b) Each day a violation exists after the notice of violation shall constitute a separate violation of this Ordinance.
 - (c) Penalties set forth in this section shall be in addition to all other remedies of injunction,

CHAPTER 11 - PUBLIC NUISANCES

TOWN OF COTTAGE GROVE - CODE OF ORDINANCES

abatement or costs whether existing under this Ordinance or otherwise.

(4) SEVERABILITY.

If any section, subsection, paragraph, clause, sentence, phrase or word contained in this Ordinance is declared invalid, the remaining portions of the Ordinance shall remain in full force and effect.

Appendix 11-A Open Burning Permit Application

**TOWN OF COTTAGE GROVE
OPEN BURNING AND CAMPFIRE PERMIT**

PERMIT VALID FOR CALENDAR YEAR _____

BURNING LOCATION _____
(Street Address, NOT PO Box)

MATERIALS TO BE BURNED _____

RESPONSIBLE PARTY NAME _____

ADDRESS _____

PHONE _____ EMAIL: _____

BURNING PERMIT CONDITIONS

**THE FOLLOWING SHALL BE COMPLIED WITH AT ALL TIMES
DURING ANY BURNING ACTIVITY**

(Check the boxes to indicate your agreement to comply)

I will call the fire department burn line (608-839-5021 ext. 112 or menu option 1) or visit the fire department web site (<http://www.cottagegrovefire.org/burn-permits.html>) to check for any burning restrictions prior to burning on the day of the burn. **As a courtesy, permit holders planning to burn an area exceeding 5 acres in size are asked to leave a message on the burn line to inform the fire department of their plans.*

I will only burn clean untreated wood, clean non-recyclable paper products and vegetation. I have considered other means of disposal such as composting and recycling.

I will not burn garbage or anything that is recyclable. This includes but is not limited to: plastic, shingles, wire, metal electronics, asphalt, painted or treated wood, rubber or oily substances, or structures of any kind (barns, sheds, homes, etc.)

All burning shall be conducted in a safe manner, when wind and weather conditions are such that they do not create any fire hazards to adjacent properties and the burning can be safely controlled.

No burning will be conducted within 20 feet from any structure, hay stack, or fuel storage location; or upon any surface within a right-of-way, public or private.

Adequate firebreaks shall be provided, and arrangements shall be made to notify the fire department in case of any emergency, [ie: having a phone available to DIAL 911].

I will not burn any waste generated by a business or commercial entity.

Any burning after dark will be contained by a fire pit or ring, and will be extinguished by 10:00 P.M. on Sunday thru Thursday and 11:00 P.M. on Friday or Saturday, or shall be extinguished immediately upon the request of a neighbor due to smoke causing a nuisance on the neighboring property.

I am 18 years of age or older.

The person who will conduct the burning is 18 years of age or older, has the physical and mental capacity to conduct any burning for which this annual burning permit is issued, and will attend the burn at all times and make certain it is completely extinguished and cold to the touch before leaving.

(Continued on reverse)

I understand that this permit may be revoked upon violation of any of its restrictions and non-compliance shall be considered a permit violation.

I understand that any violation of these conditions may result in my being held liable for the costs and other forfeitures identified in sections 11.02 and 25.04 of the code of ordinances of the Town.

I hereby agree to comply with all of the additional conditions detailed below.

**THE FOLLOWING ARE PROHIBITED WITHOUT EXCEPTION
WITHIN THE TOWN OF COTTAGE GROVE**

1. Burning of any wet combustible rubbish, garbage, oily substances, asphalt, rubber products, or other materials prohibited by NR 429.04 or 502.11, Wisconsin Administrative Code.
2. Burning of explosive or dangerous material without a permit issued either by the Wisconsin Department of Natural Resources [WDNR], or the Wisconsin Department of Safety and Professional Services [WDSPS].
3. Burning in an air curtain destructor without first obtaining a permit from the WDNR and having received written approval from the Town Board.
4. Open burning of any material whatsoever by businesses, excluding agricultural or silvicultural facilities, except where a wood burning site license under Wis. Admin. Code NR §§502.11(f) has been approved by the WDNR.
5. Open burning of any material whatsoever by agricultural or silvicultural facilities, except for stumps, trees, limbs, brush and weeds, as described in Wis. Admin. Code NR §§502.11(2)(a).

RESPONSIBLE PARTY Signature: _____ Date: _____

Permit issued by: _____ Date: _____

GENERAL NOTES

"Xφ" = DIAMETER OF THE POST PLUS 12".

FENCE STAPLES SHOULD NEVER BE DRIVEN VERTICALLY INTO WOOD POSTS (WITH BOTH LEGS PARALLEL WITH THE WOOD GRAIN). DOING SO CAN SEPARATE THE GRAIN AND SIGNIFICANTLY REDUCE THE HOLDING POWER. ROTATING THE STAPLES SLIGHTLY OFF VERTICAL STRADDLES THE GRAIN AND PROVIDES MORE RESISTANCE TO PULL-OUT.

DO NOT STAPLE WIRE TIGHT TO THE LINE POSTS. ALLOW MOVEMENT OF WIRE FOR EXPANSION AND CONTRACTION. STAPLE ARRANGEMENT SHALL BE THE SAME FOR ALL OTHER POSTS EXCEPT THAT THEY SHALL BE DRIVEN TIGHT TO POSTS. ALL STAPLES SHALL BE 2" X 9 GAGE AND SHALL BE MANUFACTURED FROM GALVANIZED WIRE OR HOT DIP GALVANIZED AFTER FORMING. STAPLES SHALL HAVE SLASH-CUT POINTS.

FENCE SHALL BE LOCATED 3'-0" INSIDE THE RIGHT OF WAY LINE UNLESS OTHERWISE INDICATED ON THE PLANS.

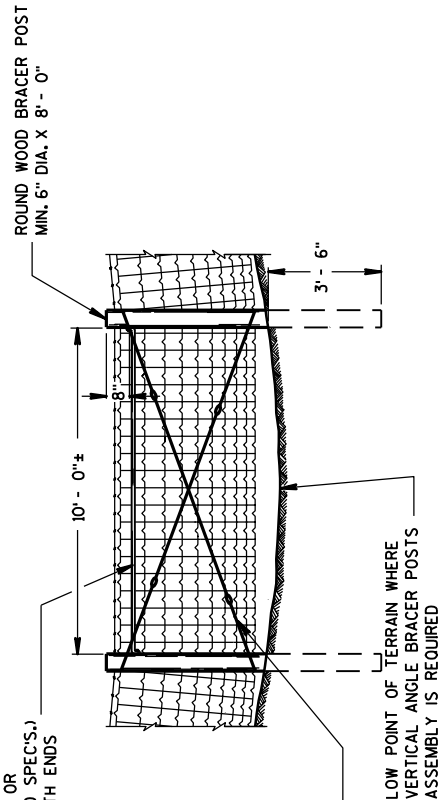

VERTICAL ANGLE BRACER POSTS ASSEMBLY

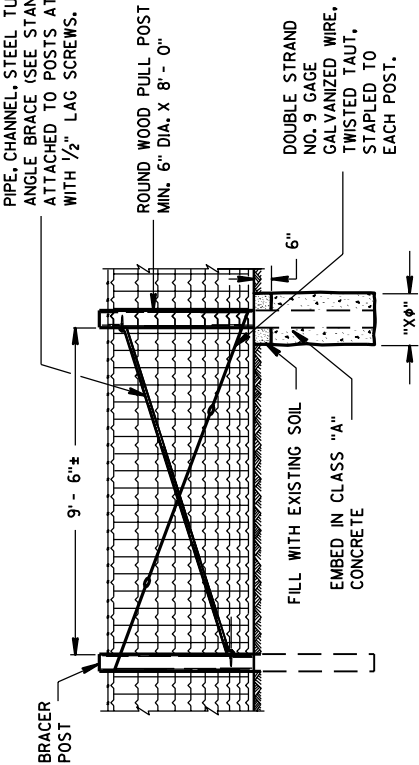

PULL OR STRETCHER POSTS ASSEMBLY

NOTE: PULL OR STRETCHER POST ASSEMBLIES SHALL BE PLACED MIDWAY BETWEEN END POSTS AND CORNER POSTS WHERE A RUN OF FENCE EXCEEDS 660' BUT IS LESS THAN 1,320'. FOR RUNS OF FENCE IN EXCESS OF 1,320' MAXIMUM SPACING OF PULL OR STRETCHER POST ASSEMBLIES SHALL BE 660'± C-C.

ILLUSTRATION SHOWS POSITION OF STANDARD STEEL BRACE, DOUBLE STRAND GALVANIZED WIRE, AND THE POST TO BE EMBEDDED IN CONCRETE WHEN WIRE FENCE IS INSTALLED FROM LEFT TO RIGHT. THE BRACES SHALL BE POSITIONED ON THE OPPOSITE DIAGONALS AND THE OPPOSITE POST SHALL BE EMBEDDED IN CONCRETE WHEN WIRE FENCE IS INSTALLED FROM RIGHT TO LEFT.

STANDARD WOVEN WIRE FENCE - TOP AND BOTTOM HORIZONTAL WIRES NO. 9 GA. ALL OTHER HORIZONTAL WIRES AND ALL VERTICAL WIRES NO. 11 GA.

ROUND WOOD END, CORNER, BRACER OR VERTICAL ANGLE POSTS MIN. 6" DIA. X 8'-0".

ROUND WOOD LINE POSTS MIN. 4 1/2" DIA. X 7'-0" - 16'-0" C-C.

NO. 11 GA. GALVANIZED STEEL WIRE CONNECTOR OR NO. 10 GA. COPPER WIRE CONNECTOR, ONE REQUIRED AT EACH GROUND ROD LOCATION.

15 1/2 GAGE MINIMUM, TWO STRAND BARBED WIRE. THE STRAND BREAKING STRENGTH SHALL BE AT LEAST 950 POUNDS. ZINC COATING SHALL NOT BE LESS THAN 0.80 OUNCE PER SQUARE FOOT OF UNCOATED SURFACE.

SIX TURNS REQUIRED AT EACH TIE POINT

GROUND ROD & SPACING SHALL CONFORM TO STANDARD SPECIFICATIONS 616.3.3

ALTERNATE METHODS OF SECURING VERTICAL STAY WIRES TO HORIZONTAL WIRES - SECURELY WELDED OR TWISTED.

PIPE, CHANNEL, STEEL TUBING OR ANGLE BRACE (SEE STANDARD SPEC'S.) ATTACHED TO POSTS AT BOTH ENDS WITH 1/2" LAG SCREWS.

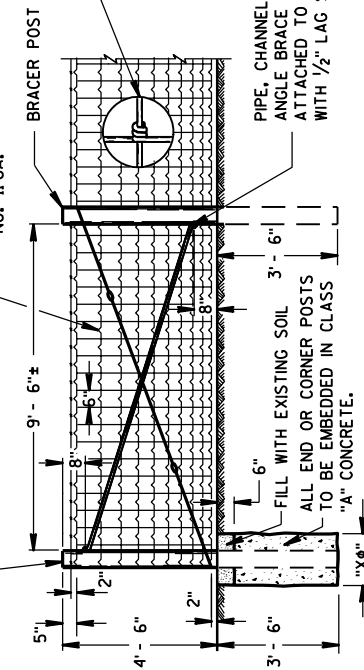

NOTE: FENCE CORNERS - ABOVE ILLUSTRATION SHOWS ONE LEG OF FENCE CONSTRUCTION AT FENCE CORNER. THE CONTIGUOUS LEG TO BE IDENTICAL CONSTRUCTION.

END OR CORNER POSTS ASSEMBLY

LINE FENCE CONSTRUCTION

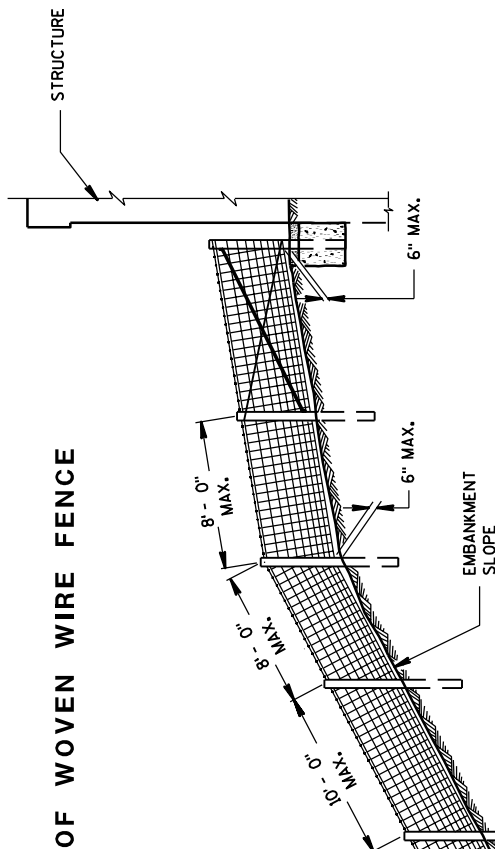

GENERAL ROADSIDE VIEW OF WOVEN WIRE FENCE

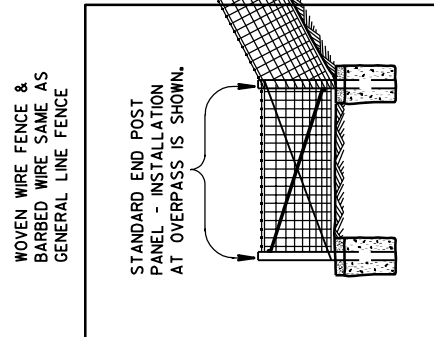

ALTERNATE FENCE DESIGN AT STRUCTURE

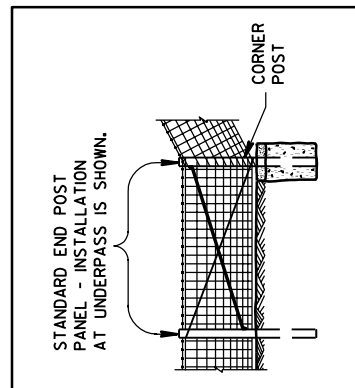

FENCE DESIGN AT STRUCTURE APPROACH

FENCE WOVEN WIRE

STATE OF WISCONSIN
DEPARTMENT OF TRANSPORTATION

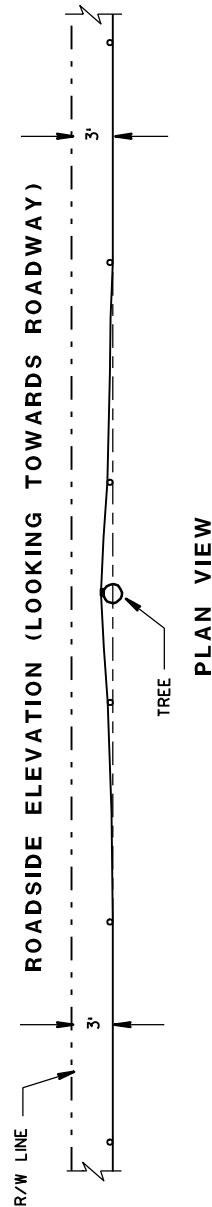
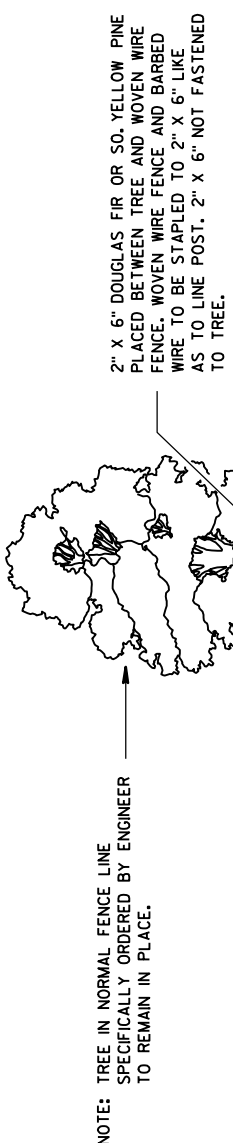

FENCE DESIGN AT TREES REMAINING IN NORMAL FENCE LINE

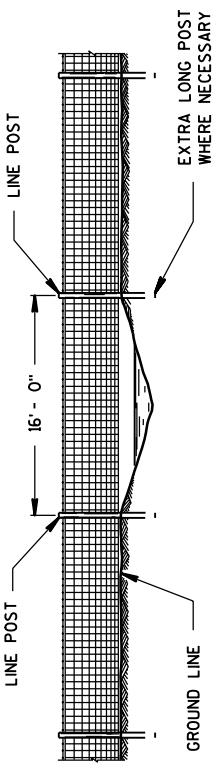

FENCE CONSTRUCTION OVER STREAM COURSES OF 15 FT. OR LESS IN WIDTH

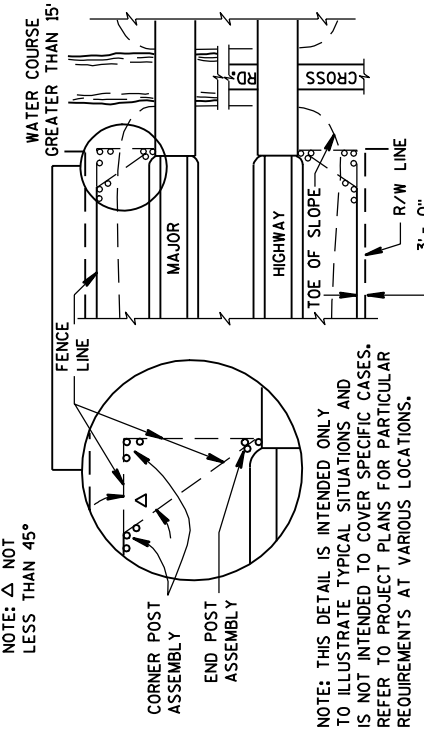

MAJOR HIGHWAY OVERPASS OR STREAM COURSE CROSSING OF GREATER THAN 15 FT. IN WIDTH

FENCE LOCATION AT STRUCTURES

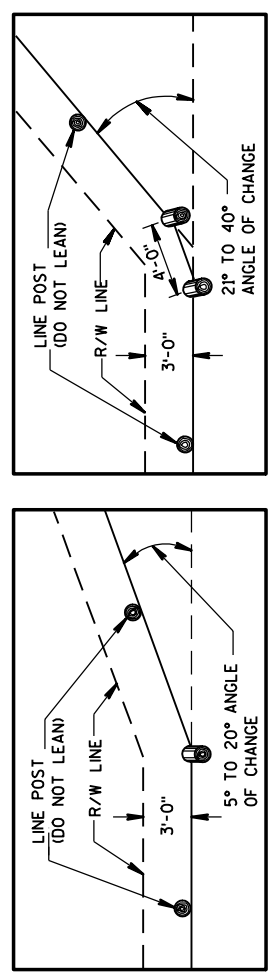

PLAN VIEW SINGLE POST CORNER

RIGHT OF WAY LINE CHANGE 40° AND LESS

NOTE: SINGLE AND DOUBLE POSTS SHALL BE A MIN. 6" DIA. X 8'-0" WITH A LEAN OF 4" TOWARD THE OUTSIDE OF THE CURVE. WHEN THE RIGHT OF WAY LINE CHANGE IS MORE THAN 40° USE THE CORNER OR STRETCHER POSTS ASSEMBLY.

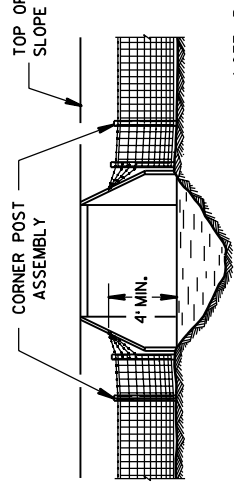

NOTE: PLACE A MINIMUM OF 4 STRANDS OF BARBED WIRE, 6" MAXIMUM CENTERS IN FAN SHAPE CONNECTED TO AN EYE BOLT ON WINGWALL OR SET A LONE POST WHEN NECESSARY TO CONNECT BARBED WIRE.

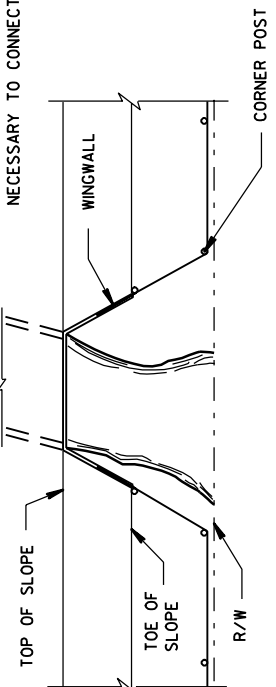

FENCE INSTALLATION TO WINGWALLS

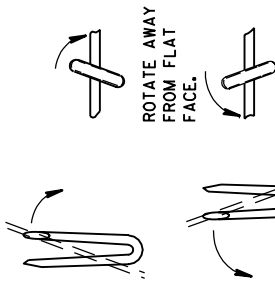

LINE POST

NOTE: WHEN POSTS ARE DRIVEN THE SMALL END SHALL BE DOWN.

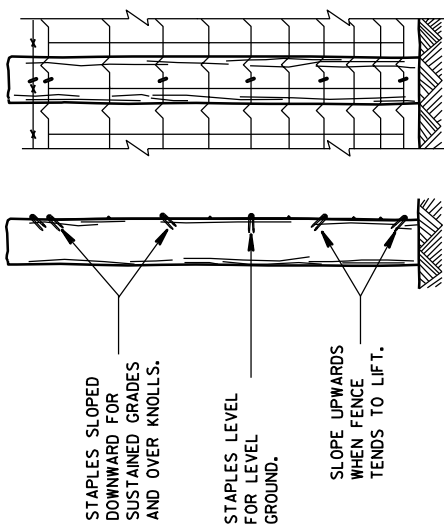

END ELEVATION SIDE ELEVATION FENCE MOUNTING DETAIL

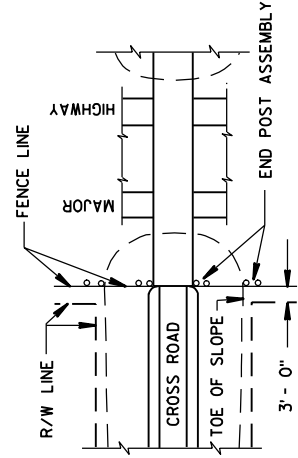

MAJOR HIGHWAY UNDERPASS

PLAN VIEW

NOTE: THIS DETAIL IS INTENDED ONLY TO ILLUSTRATE TYPICAL SITUATIONS AND IS NOT INTENDED TO COVER SPECIFIC CASES. REFER TO PROJECT PLANS FOR PARTICULAR REQUIREMENTS AT VARIOUS LOCATIONS.

FENCE WOVEN WIRE	
STATE OF WISCONSIN	DEPARTMENT OF TRANSPORTATION
APPROVED	DATE
4/4/08	/S/ JERRY H. ZOGG
	ROADWAY STANDARDS DEVELOPMENT ENGINEER
	FHWA

ORIGINAL

TOWN OF COTTAGE GROVE

COTTAGE GROVE, WISCONSIN 53527

SELF-CLOSING / CHILD RESISTANT GATE HARDWARE

AUTOMATIC LATCHES

Chain Link Fence

Wood Fence

Maxima Post Latch



Universal Heavy-Duty Gravity Latch

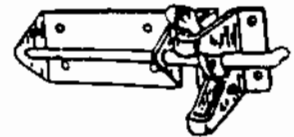

AUTO-LATCH DIAGRAM

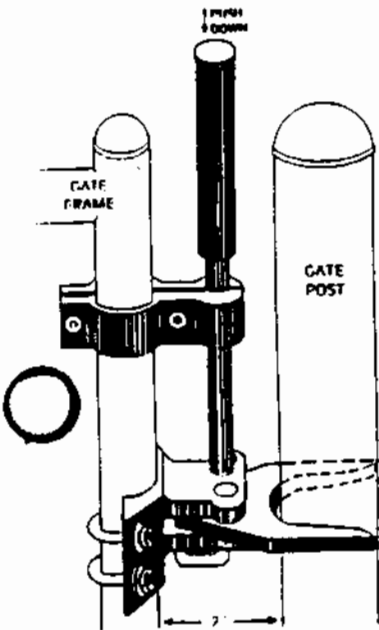

GATE BUTTERFLY LATCH
Pressed Steel Ear
Aluminum Back with U-Bolt



**ALL HARDWARE SHOWN ON THIS PAGE IS
AVAILABLE LOCALLY FOR LESS THAN \$25.**

AUTOMATIC CLOSERS

Chain Link Fence

Wood Fence

Continental Spring-Loaded Tee Hinge



GATE HINGE CLOSER
COMPLETE - Gravity Type

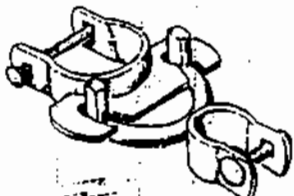

GATE CLOSER
Spring Type



Gate Spring



TOWN OF COTTAGE GROVE - CODE OF ORDINANCES

APPENDIX 11-C

TABLE G-16—PERMISSIBLE NOISE EXPOSURES ¹

<i>Duration per day, hours</i>	<i>Sound level dba slow response</i>
8	90
6	92
4	95
3	97
2	100
1 1/2	102
1	105
1/2	110
1/4 or less	115

¹ When the daily noise exposure is composed of two or more periods of noise exposure of different levels, their combined effect should be considered, rather than the individual effect of each. If the sum of the following fractions: $C_1/T_1 + C_2/T_2 + C_n/T_n$ exceeds unity, then, the mixed exposure should be considered to exceed the limit value. C_n indicates the total time of exposure at a specified noise level, and T_n indicates the total time of exposure permitted at that level.

Exposure to impulsive or impact noise should not exceed 140 dB peak sound pressure level.